

1. HEAVY DUTY POLYETHYLENE CONSTRUCTION
2. 1 PIECE ROTATIONALLY MOLDED
3. TRANSLUCENT
4. FDA APPROVED RESIN AVAILABLE
5. CALIBRATED IN GALLONS
6. UV STABILIZED
7. SPECIFIC GRAVITY IS 1.75

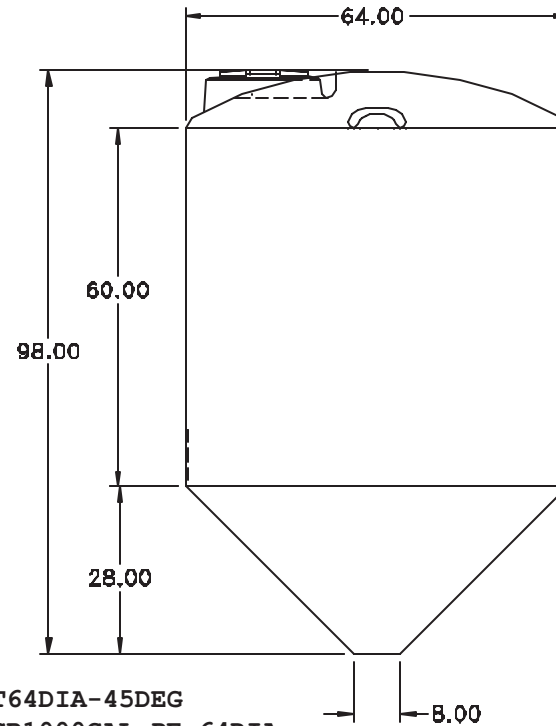
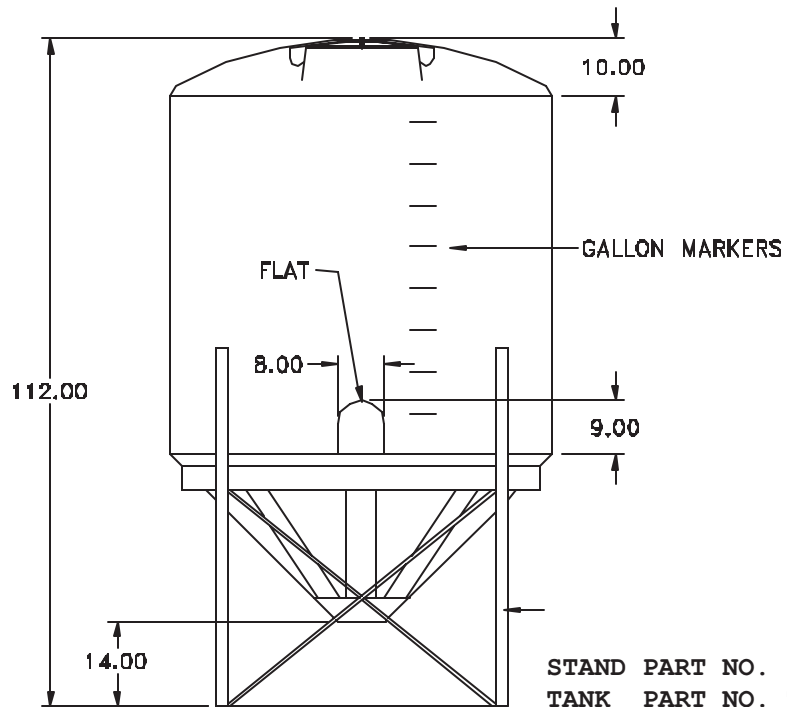

STAND PART NO. ST64DIA-45DEG  
 TANK PART NO. TCB1000GAL-PE-64DIA

REV	DESCRIPTION	DATE	APPRD

DRAWN / DATE	EDB/5/7/96
APPRD. / DATE	

MATERIAL / SHOT WEIGHT			
M111	M134	U625	P938
250			

**CSI**  
 ChemIndustrial Systems, Inc.  
 PO Box 500, Cedarburg, WI 53012  
 262-375-8570 • (Fax) 262-375-8559 • info@chemindustrial.com  
 PART NO. TCB1000GAL-PE-64DIA, ST64DIA-45DEG

SCALE	N.S.	PART NO. TCB1000GAL-PE-64DIA
-------	------	------------------------------

ALL DIMENSIONS ARE IN DECIMAL INCHES  
 TOLERANCES UNLESS OTHERWISE SPECIFIED  
 ± .5% @ 68° F

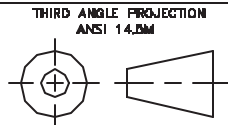

NOTES: