

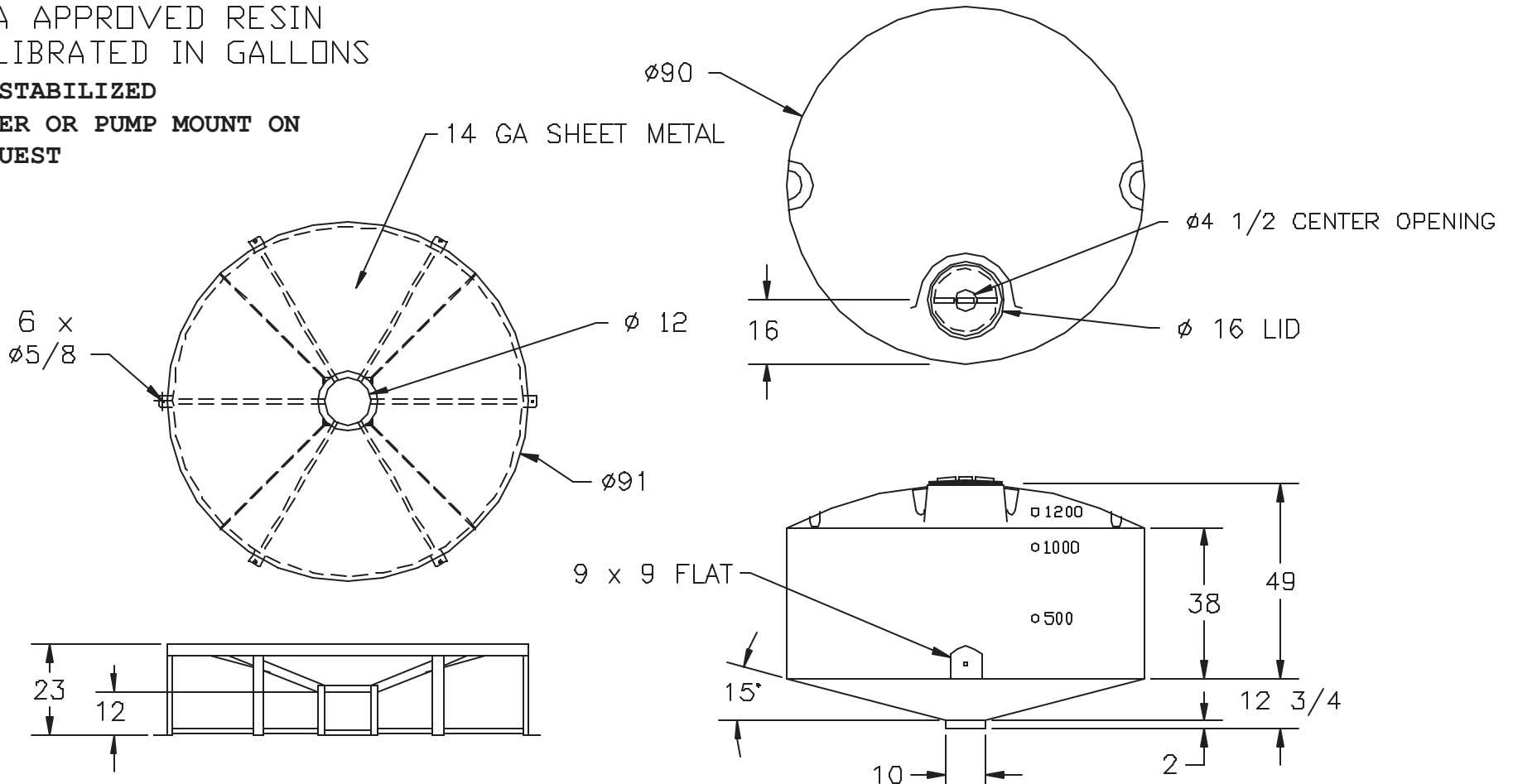
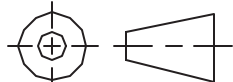

1. SPECIFIC GRAVITY IS 1.75
2. 1 PIECE ROTATIONALLY MOLDED
3. TRANSLUCENT
4. FDA APPROVED RESIN
5. CALIBRATED IN GALLONS
6. **UV STABILIZED**
7. **MIXER OR PUMP MOUNT ON REQUEST**



STAND PART NO. ST90DIA-15DEG  
 TANK PART NO. TCB1200GAL-PER-90DIA

DRAWN <b>DEAN</b>		DATE <b>3-2-95</b>		MATERIAL <b>POLYETHYLENE</b>		 <b>ChemIndustrial Systems, Inc.</b> PO Box 500, Cedarburg, WI 53012 262-375-8570 • (Fax) 262-375-8559 • info@chemindustrial.com PART NO. TCB1200GAL-PE-90DIA, ST90DIA-15DEG	
APPROVED		DATE		PART WEIGHT <b>225 LBS.</b>			
REV	DESCRIPTION	DATE	APVD	THIRD ANGLE PROJECTION		SIZE <b>A</b>	DWG NO. TCB1200GAL-PE-90DIA
SCALE <b>NONE</b>						REV	
UDS DIMENSIONS ARE IN INCHES GENERAL TOLERANCES ± .5% @ 68° F							