

1. HEAVY DUTY POLYETHYLENE CONSTRUCTION
2. 1 PIECE ROTATIONALLY MOLDED
3. TRANSLUCENT
4. FDA APPROVED RESIN AVAILABLE
5. CALIBRATED IN GALLONS
6. UV STABILIZED
7. SPECIFIC GRAVITY IS 1.75

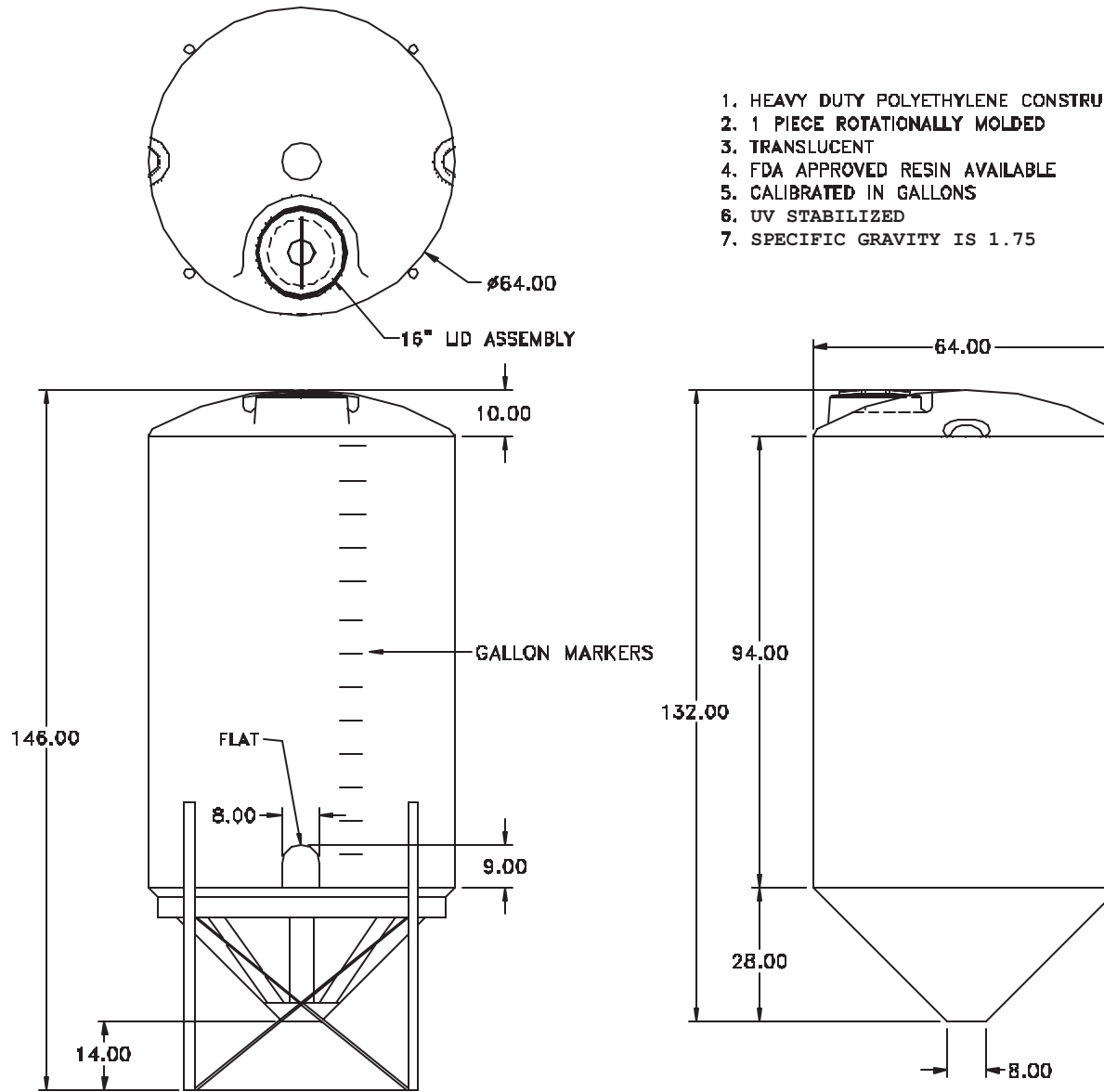

STAND PART NO. ST64DIA-45DEG
 TANK PART NO. TCB1490GAL-PE-64DIA

REV	DESCRIPTION	DATE	APPRD

DRAWN / DATE EDB/5/7/96
APPRD. / DATE

MATERIAL / SHOT WEIGHT			
M111	M134	U625	P938
340			

CSI
 ChemIndustrial Systems, Inc.
 PO Box 500, Cedarburg, WI 53012
 262-375-8570 • (Fax) 262-375-8559 • info@chemindustrial.com
 PART NO. TCB1490GAL-PE-64DIA, ST64DIA-45DEG

ALL DIMENSIONS ARE IN DECIMAL INCHES
 TOLERANCES UNLESS OTHERWISE SPECIFIED
 ± .5% @ 68° F

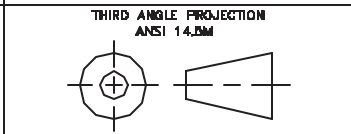

NOTES:

SCALE N.S.

PART NO. TCB1490GAL-PE-64DIA