

1. SPECIFIC GRAVITY IS 1.75
2. 1 PIECE ROTATIONALLY MOLDED
3. TRANSLUCENT
4. FDA APPROVED RESIN
5. CALIBRATED IN GALLONS
6. UV STABILIZED
7. MIXER OR PUMP MOUNT ON REQUEST

STAND PART NO. ST85DIA-45DEG
 TANK PART NO. TCB2600GAL-PE-85DIA

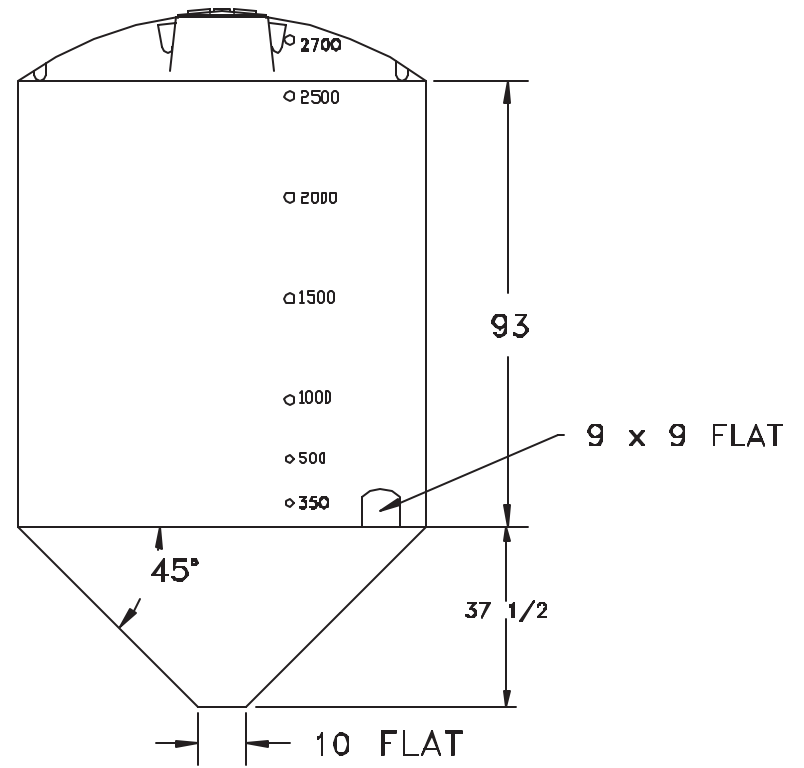
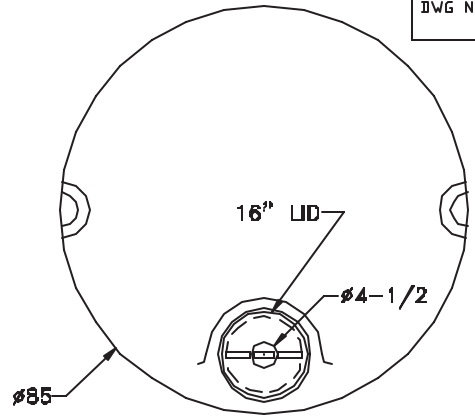
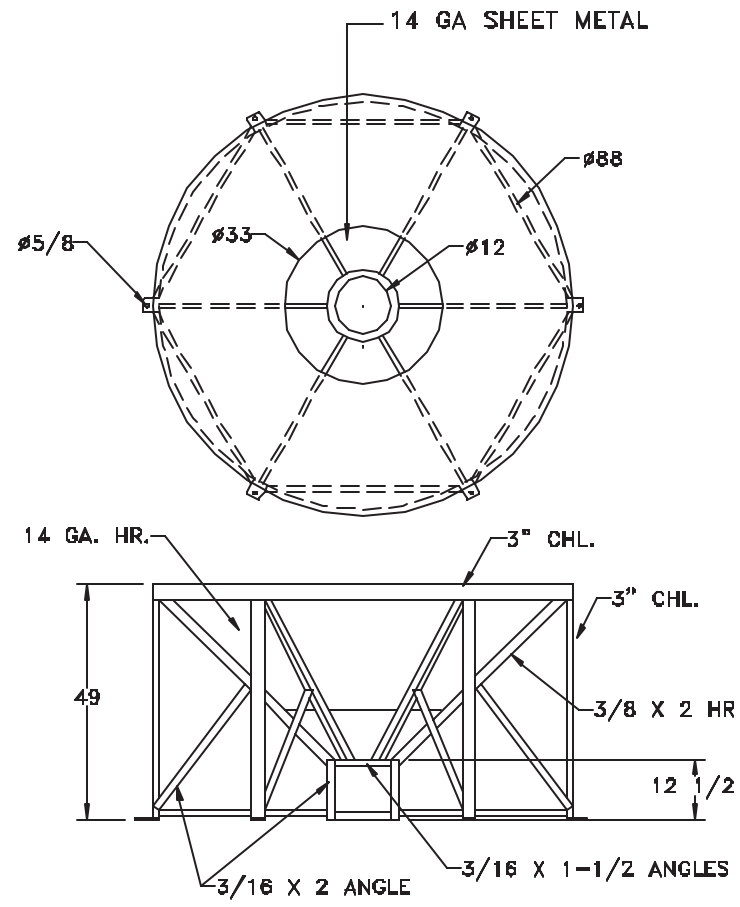

REV	DESCRIPTION	DATE	APVD	DRAWN DEAN	DATE 12-9-93	MATERIAL HIGH DENSITY POLYETHYLENE
SCALE	NONE			APPROVED	DATE	PART WEIGHT 500 LBS.
UDS DIMENSIONS ARE IN INCHES GENERAL TOLERANCES ± .5% @ 68° F				THIRD ANGLE PROJECTION 		

CSI
 ChemIndustrial Systems, Inc.
 PO Box 500, Cedarburg, WI 53012
 262-375-8570 • (Fax) 262-375-8559 • info@chemindustrial.com
 PART NO. TCB2600GAL-PE-85DIA, ST85DIA-45DEG

SIZE A	DWG NO. TCB2600GAL-PE-85DIA	REV
------------------	-----------------------------	-----