

1. SPECIFIC GRAVITY IS 1.7
2. 1 PIECE ROTATIONALLY MOLDED
3. TRANSLUCENT
4. FDA APPROVED RESIN
5. CALIBRATED IN GALLONS
6. UV STABILIZED
7. MIXER OR PUMP MOUNT ON REQUEST

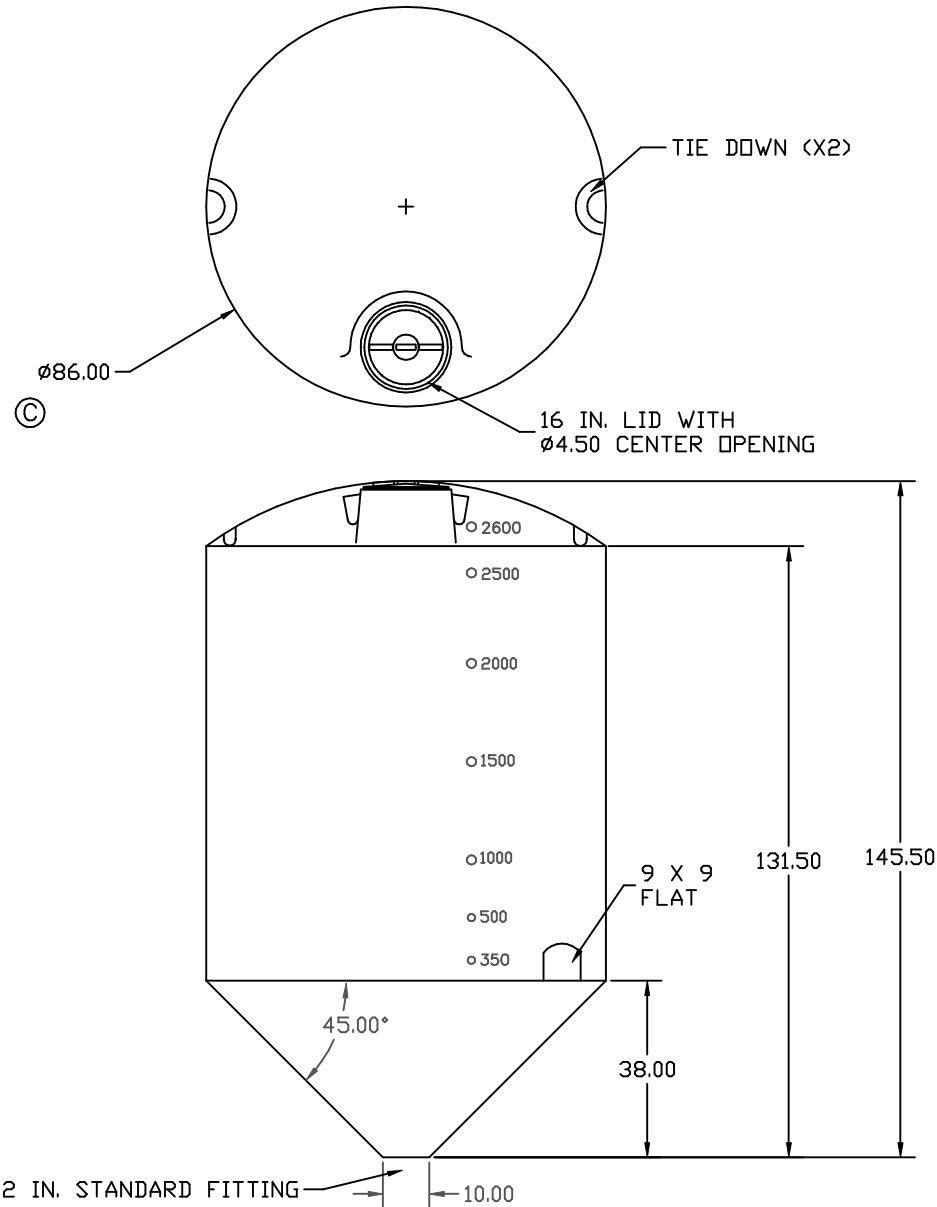

C	DIAMETER WAS 85	7/31/06	NVE	DRAWN / DATE	MATERIAL
B	UPDATED DIMENSIONS	7/13/06	NVE	DHJ 12/9/93	
A	ISOLATED TANK AND STAND	6/13/06	NVE	APPRD. / DATE	HDPE OR EQUIVALENT REFERENCE MATERIAL DATA SHEET FOR SPECIFIC PROPERTIES.
REV	DESCRIPTION	DATE	APPRD		

ALL DIMENSIONS ARE IN DECIMAL INCHES
TOLERANCES UNLESS OTHERWISE SPECIFIED
± 1% @ 68° F

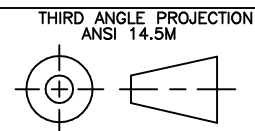

NOTES:
1. NOM. WALL @ 0.369
2. SHOT WEIGHT 500 LBS.

CSI
ChemIndustrial Systems, Inc.
PO Box 500, Cedarburg, WI 53012
262-375-8570 • (Fax) 262-375-8559 • info@chemindustrial.com

SCALE	N.S.	PART NO.
-------	------	----------