

← GO BACK

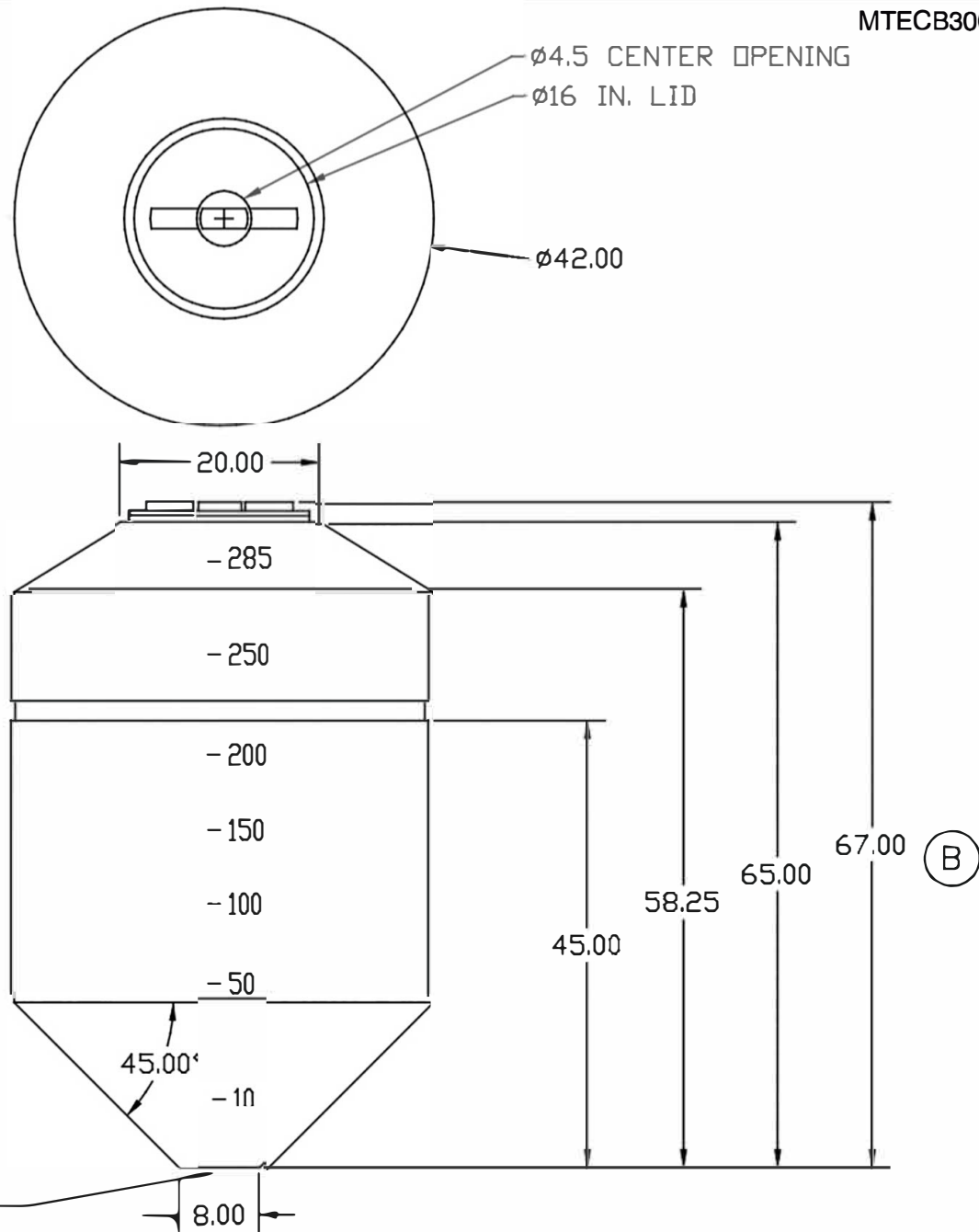

2 IN FITTING STANDARD

(B)

|   |                         |         |       |  |   |
|---|-------------------------|---------|-------|--|---|
|   |                         |         |       | DRAWN / DATE<br>DHJ 1/20/03              | MATERIAL  |
| B   | HEIGHT WAS 66.00        | 7/10/06 | NVE   |  | HDPE OR EQUIVALENT<br>REFERENCE MATERIAL DATA SHEET<br>FOR SPECIFIC PROPERTIES. |
| A   | ISOLATED STAND AND TANK | 6/6/06  | NVE   | APPRD. / DATE                            |   |
| REV   | DESCRIPTION             | DATE    | APPRD |  |   |
| ALL DIMENSIONS ARE IN DECIMAL INCHES<br>TOLERANCES UNLESS OTHERWISE SPECIFIED<br>± 1% @ 68° F |                         |         |       | THIRD ANGLE PROJECTION<br>ANSI 14.5M<br> | NOTES:<br>1. NOM. WALL @ .322<br>2. SHOT WEIGHT 100 LBS.                        |



**ChemIndustrial Systems, Inc.**  
PO Box 500, Cedarburg, WI 53012  
262-375-8570 • (Fax) 262-375-8559 • info@chemindustrial.com

|               |                                     |
|---------------|-------------------------------------|
| SCALE<br>N.S. | PART NO.<br>MTECB300GAL-PE-42DIA-DT |
|---------------|-------------------------------------|